



Main Features:-

- ◆ 3 Way Flanged PN16 Ball Valve
- ◆ Series 10123 - L Port
- ◆ Series 10127 - T Port
- ◆ RPTFE seats and Viton Seals
- ◆ -20 to +180C Temperature Rating PN16

*Temperature and pressure determined by valve body, seat etc.



Suitable Applications & Approvals:



SERIES: 10123/10127

MANUFACTURER: **AVOL**
INDUSTRIAL VALVES

VALVE DIMENSIONS

SIZE	CODE	D	G	T	F	N	M	L	H	W	Kg	Nm	ISO	Stem
1/2"	10123/10127-04	95	45	16	2	4	14	160	80	123	4.6		F03-04	9
3/4"	10123/10127-05	105	58	18	2	4	14	165	84	123	6.2		F03-04	9
1"	10123/10127-06	115	68	18	2	4	14	180	96	153	9.3		F04-05	11
1 1/4"	10123/10127-07	140	78	78	3	4	18	234	171	403	14.4		F07	17
1 1/2"	10123/10127-08	150	88	88	3	4	18	234	171	403	165.5		F07	17
2"	10123/10127-09	165	102	102	3	4	18	273	176	403	19.6		F07	17
2 1/2"	10123/10127-10	185	122	122	3	4	18	300	208	504	27.5		F10	22
3"	10123/10127-11	200	138	138	3	8	18	305	216	504	35.4		F10	22
4"	10123/10127-12	220	158	158	3	8	18	369	236	504	59.2		F10	22
6"	10123/10127-14	285	212	212	3	8	22	480	329	800	144.9		F14	36

DIMENSIONAL DRAWING OF VALVE

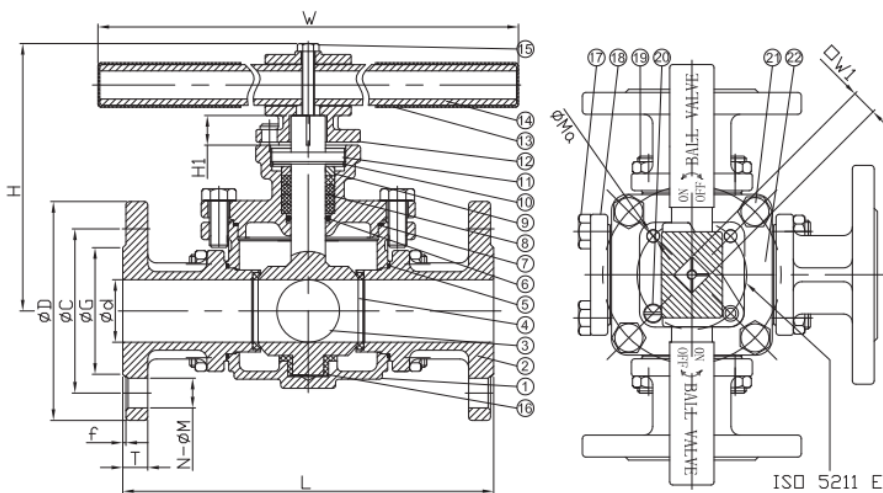

MATERIALS OF CONSTRUCTION

BODY	CF8M SS
BALL	CF8M
BODY SEAT	RPTFE
STEM	316 SS
ORINGS	VITON
PRESSURE	PN16
TEMP	-20 to +180C

T +44 (0)1386 552369

W www.allvalves.co.uk

E sales@allvalves.co.uk

F +44 (0)1386 554227